STOCHASTIC MODEL ANALYSIS OF THE IMPACT OF MEDIA CAMPAIGN ON TRANSMISSION OF COVID – 19 EPIDEMICS.

Bashiru K. Adekunle¹, Ojurongbe T. Adetola², Olaosebikan M. Lawal³, Adeboye

N. Olawale⁴, Olukotun Ifeoluwa⁵, Afolabi H. Abiodun⁶

^{1,2,3,4,5} Osun State University, Department of Statistics, P.M.B 4494 Osogbo, Nigeria.

e-mail: kehindebashiru@uniosun.edu.ng

Abstract

The COVID - 19 pandemic is currently causing authorities and public health officials more concern. The goal of the project is to convert a deterministic model for COVID-19 transmissions to a stochastic model, and then analyze the results to see how media-driven awareness campaigns have an impact on the disease's spread. The dynamic COVID-19 model was converted to a stochastic model, which was then examined. The model includes the following categories: Susceptible (S), Exposed (E), Infected class (I), Isolated class (I_s), Aware class (S_m) and Recovered class (R), as well as the Cumulative density of awareness programs by media denoted by M (S, E, I, I_s, S_m, R, M). With the help of MATLAB, the converted model is then numerically solved using the Eula Maruyama approach, allowing the existence and uniqueness of the model to be examined. The implementation of awareness programs has been found to have a significant positive impact on the spread of COVID-19. As the rate of implementation of these programs rises, the population that is exposed to the virus and those who are infected with it declines, and it has been hypothesized that this will eventually cause COVID-19 to become extinct. According to the report, putting awareness campaigns into place can help stop the COVID-19 epidemic from spreading.

Keywords: COVID - 19, Stochastic Model, Eula - Maruyama, Transition Probability, Media Campaign.

1. INTRODUCTION

The Covid - 19 epidemic is currently causing authorities and public health officials more anxiety. Due to the vast number of infected and fatalities reported worldwide, it is regarded as the greatest global menace. The World Health Organization (WHO) reported that 539906 people had died and 11669259 had been confirmed as having the disease as of July 8th, 2020 (Ayinde *et al* 2020). The COVID-19 Pandemic is primarily spread by close contact (effective contact), particularly through the minute beads created by coughing, sneezing, or speaking. The main symptoms include persistent chest pain or pressure, fever, headache, loss of taste and smell, runny nose, and diarrhea.

Mathematical modeling has been used to examine the dynamics of many complicated COVID-19 systems, both physically and physiologically (Nesteruk 2020), (Liu *et al* 2020), (Tang *et al* 2020). Since the disease was identified as the greatest global threat, mathematical models have been developed to examine how the pandemic spreads (see [(Asamoah *et al* 2020), (Asamoah *et al* 2020), (Abdo *et al* 2020), (Al – qaness *et al* 2020), (Anastassopoulou *et al* 2020), Ayinde *et al* 2020), (Engbert *et al* 2020), (Hay 2019) and (Rihan *et al* 2020)], and the deterministic model is the most used one in modeling studies of COVID-19). Even though, a deterministic model yields the same outcomes under identical circumstances, and it is well known that the parameters utilized in a mathematical model of a communicable disease are subject to change in various experiments [(Jumane and Naboth 2020), Zafer *et al* 2020)]. Since most deterministic

models presume that all input variables are functions of time and that biological processes are stochastic, neglecting their fundamental randomness is likely to provide findings that are inaccurate and misleading (Ndairou *et al* 2018), (Ndi and Supriatna 2017), (Nesteruk 2020)

The stochastic component of the COVID-19 pandemic has also been rigorously explored by a number of writers [(He and Libin 2020),(Mohammed and Modeste 2021),(Rihan *et al* 2020),(Sultan *et al* 2020) and Zizhen *et al* 2020)]. The proposed deterministic model was transformed to a stochastic model for this investigation. Euler Maruyama was used for numerical simulations, and MATLAB was used for analysis.

2. RESEARCH METHOD

The expanded SEIR model was used in this study to simulate the COVID-19 epidemic in Nigeria. The model took into account the entire population as (N), and it divided the human population at time (t) into seven (7) sub classes: Susceptible (S), Exposed (E), Infected class (I), Isolated class (I_s), Aware class (S_m) and Recovered class (R), as well as the Cumulative density of awareness programs by media denoted by. It is also assumed that only contact between susceptible and infected people causes COVID-19 to spread. The pace at which new people enter the susceptible population through births and immigration is indicated by the number. As a result of the awareness campaigns, Susceptible people create a distinct class and stay away from infected people .

Let λ be the rate of dissemination of awareness among Susceptible, which results in the creation of another class, λ_0 the rate of transfer of aware people to the susceptible class, k is the rate of implementation of awareness programs, and k_0 the rate of depletion of these programs as a result of sociological issues. These sociological issues include the lack of palliatives during the lockdown and religious prohibitions on the use of alcohol-based hand sanitizer. Let β be the transmission rate from Susceptible to the Exposed class

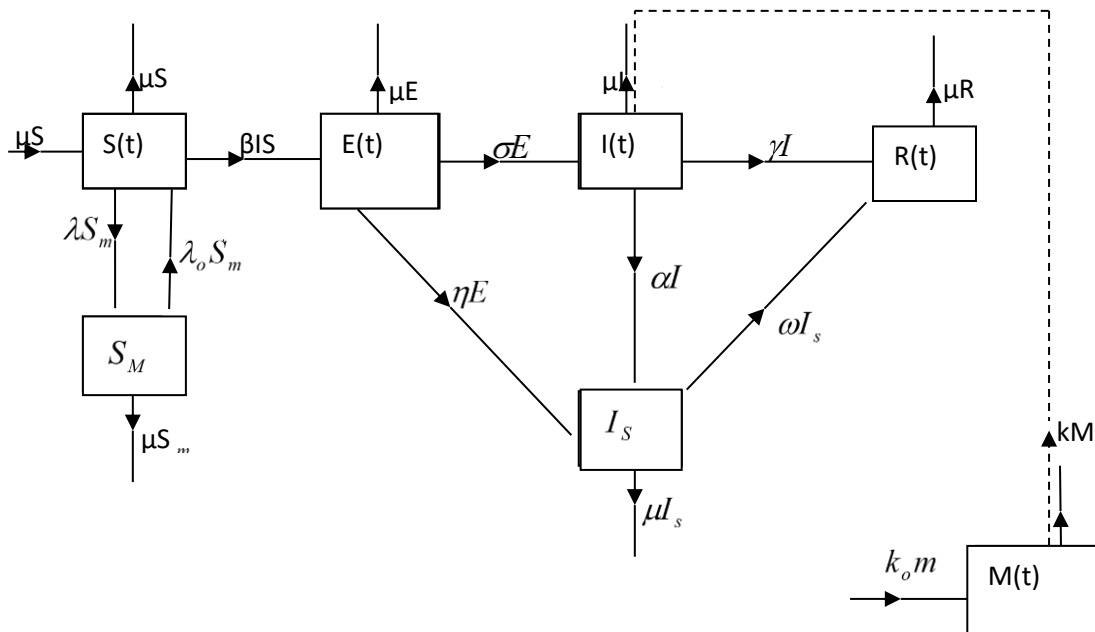

Figure 1. Schematic Diagram of the proposed COVID-19 model

Based on the information above and earlier research(Stephen *et al* 2015), (Misra *et al* 2011),(Kumama and Koya 2019), (He and Libin 2020),(Liu *et al* 2020), the dynamics of the model are controlled by the following system of non-linear differential equations

$$\left. \begin{aligned} \frac{dS}{dt} &= \Lambda - \beta SI - \mu S + \lambda_0 S_m - \lambda SM \\ \frac{dE}{dt} &= \beta SI - (\sigma + \eta + \mu)E \\ \frac{dI}{dt} &= \sigma E - (\gamma + \alpha + \nu + \mu)I \\ \frac{dI_s}{dt} &= \eta E + \alpha I - (\omega + \mu)I_s \\ \frac{dS_m}{dt} &= \lambda SM - (\mu + \lambda_0)S_m \\ \frac{dR}{dt} &= \gamma I + \omega I_s - \mu R \\ \frac{dM}{dt} &= kI - k_0 M \end{aligned} \right\} \quad (1)$$

Where $S(0) \geq 0, E(0) \geq 0, I(0) \geq 0, I_s(0) \geq 0, S_m(0) \geq 0, R(0) \geq 0, M(0) \geq 0$. The parameters of the model (2.1) are presented in table 1 below.

Due to the fact that $S + E + I + I_s + S_m + R = N$. The above system reduces to the following system.

$$\left. \begin{aligned} \frac{dN}{dt} &= \Lambda - \mu N - \nu I \\ \frac{dE}{dt} &= \beta(N - E - I - I_s - S_m - R)I - (\sigma + \eta + \mu)E \\ \frac{dI}{dt} &= \sigma E - (\gamma + \alpha + \nu + \mu)I \\ \frac{dI_s}{dt} &= \eta E + \alpha I - (\omega + \mu)I_s \\ \frac{dS_m}{dt} &= \lambda(N - E - I - I_s - S_m - R)M - (\mu + \lambda_0)S_m \\ \frac{dR}{dt} &= \gamma I + \omega I_s - \mu R \\ \frac{dM}{dt} &= kI - k_0 M \end{aligned} \right\} \quad (2)$$

2.1 The reproduction Number (R_0)

The numerical value of basic reproductive number indicates the status of endemic in the population. Going by [(Van and Watmough 2020) and (Ming *et al* 2020)], Let G be a next generation matrix which comprises of two parts F and V^{-1} where

$$F = \left[\frac{\partial F_i(x_0)}{\partial x_j} \right] \quad V = \left[\frac{\partial V_i(x_0)}{\partial x_j} \right]$$

F_i is the new infections, while the V_i transfers of infections from one compartment to another. X_0 is the disease free equilibrium state.

$$G = FV^{-1} \tag{3}$$

we are concerned with E, I and I_s compartments of the model (2). Thus

$$\left. \begin{aligned} \frac{dE}{dt} &= \beta(N - E - I - I_s - S_m - R)I - (\sigma + \eta + \mu)E \\ \frac{dI}{dt} &= \sigma E - (\gamma + \alpha + \nu + \mu)I \\ \frac{dI_s}{dt} &= \eta E + \alpha I - (\omega + \mu)I_s \end{aligned} \right\} \tag{4}$$

Hence, we have

$$R_0 = \frac{\beta\sigma}{(\sigma + \eta + \mu)(\gamma + \alpha + \mu)} \tag{5}$$

2.2 Stochastic Model Equations

The stochastic model equations of the above deterministic model can be obtained using the method proposed by [(Allen et al 2008), Allen 2008), Allen and Jr (2012) and Mohammed and modeste 2021)].

The drift vector is defined as;

$$\vec{f} = \sum_{i=1}^{18} p_i \vec{\lambda}_i, \tag{6}$$

where p_i and $\vec{\lambda}_i$ are transition probabilities and random changes respectively,

Table 1: Transition Probabilities

Random Changes ($\vec{\lambda}_i$)	Probability (p_i)	Event
$[1 \ 0 \ 0 \ 0 \ 0 \ 0 \ 0]^T$	$p_1 = \Lambda \Delta t$	Birth of a Susceptible
$[-1 \ 0 \ 0 \ 0 \ 0 \ 0 \ 0]^T$	$p_2 = \mu S \Delta t$	Susceptible dies natural death
$[-1 \ 1 \ 0 \ 0 \ 0 \ 0 \ 0]^T$	$p_3 = \beta SI \Delta t$	Susceptible becomes Exposed
$[-1 \ 0 \ 0 \ 0 \ 1 \ 0 \ 0]^T$	$p_4 = \lambda SM \Delta t$	Susceptible becomes Aware

$[0 \quad -1 \quad 0 \quad 0 \quad 0 \quad 0 \quad 0]^T$	$p_5 = \mu E \Delta t$	Exposed individual dies Natural death
$[0 \quad -1 \quad 0 \quad 1 \quad 0 \quad 0 \quad 0]^T$	$p_6 = \eta E \Delta t$	Exposed individual becomes Isolated
$[0 \quad -1 \quad 1 \quad 0 \quad 0 \quad 0 \quad 0]^T$	$p_7 = \sigma E \Delta t$	Exposed individual becomes Infected
$[0 \quad 0 \quad -1 \quad 0 \quad 0 \quad 0 \quad 0]^T$	$p_8 = \mu I \Delta t$	Infectious individual dies Natural death
$[0 \quad 0 \quad -1 \quad 1 \quad 0 \quad 0 \quad 0]^T$	$p_9 = \alpha I \Delta t$	Infectious individual Isolated
$[0 \quad 0 \quad -1 \quad 0 \quad 0 \quad 1 \quad 0]^T$	$p_{10} = \gamma I \Delta t$	Infectious individual Recovers
$[0 \quad 0 \quad -1 \quad 0 \quad 0 \quad 0 \quad 0]^T$	$p_{11} = \nu I \Delta t$	Infectious individual dies disease induced death
$[0 \quad 0 \quad 0 \quad -1 \quad 0 \quad 0 \quad 0]^T$	$p_{12} = \mu I_s \Delta t$	Isolated individual die Naturally
$[0 \quad 0 \quad 0 \quad -1 \quad 0 \quad 1 \quad 0]^T$	$p_{13} = \omega I_s \Delta t$	Isolated individual Recovers
$[0 \quad 0 \quad 0 \quad 0 \quad -1 \quad 0 \quad 0]^T$	$p_{14} = \mu S_m \Delta t$	Aware class dies Naturally
$[1 \quad 0 \quad 0 \quad 0 \quad -1 \quad 0 \quad 0]^T$	$p_{15} = \lambda_o S_m \Delta t$	Aware class becomes Susceptible
$[0 \quad 0 \quad 0 \quad 0 \quad 0 \quad -1 \quad 0]^T$	$p_{16} = \mu R \Delta t$	Recovered individual die Naturally
$[0 \quad 0 \quad 0 \quad 0 \quad 0 \quad 0 \quad 1]^T$	$p_{17} = k I \Delta t$	Media (Awareness program are implemented)
$[0 \quad 0 \quad 0 \quad 0 \quad 0 \quad 0 \quad -1]^T$	$p_{18} = \kappa_o M \Delta t$	Reduction in awareness program due to the population

$$\vec{f} = \sum_{i=1}^{18} p_i \vec{\lambda}_i$$

The drift vector \vec{f} of order 7×1 , is given by

$$\vec{f} = \left\{ \begin{array}{l} \Lambda - \mu N - \nu I \\ \beta(N - E - I - I_s - S_m - R)I - (\sigma + \eta + \mu)E \\ \sigma E - (\gamma + \alpha + \nu + \mu)I \\ \eta E + \alpha I - (\omega + \mu)I_s \\ \lambda(N - E - I - I_s - S_m - R)M - (\mu + \lambda_o)S_m \\ \gamma I + \omega I_s - \mu R \\ kI - \kappa_o M \end{array} \right\} \quad (7)$$

Where V is the covariance matrix, given as :

$$V = \sum_{i=1}^{18} p_i \vec{\lambda}_i \vec{\lambda}_i^T \quad (8)$$

Thus, we obtained the covariance matrix v of order 7×7 as

$$V = \begin{pmatrix} a_{11} & a_{12} & 0 & 0 & -a_{13} & 0 & 0 \\ a_{12} & a_{14} & a_{15} & -\eta E & 0 & 0 & 0 \\ 0 & -a_{16} & a_{17} & 0 & 0 & -\gamma I & 0 \\ 0 & -\sigma E & 0 & \omega I_s & 0 & -\omega I_s & 0 \\ a_{13} & 0 & 0 & 0 & a_{13} & 0 & 0 \\ 0 & 0 & -\gamma I & -\omega I_s & 0 & a_{18} & 0 \\ 0 & 0 & 0 & 0 & 0 & 0 & a_{19} \end{pmatrix}$$

where

$$a_{11} = \Lambda + \mu S + \beta SI + \lambda SM + \lambda_o S_m, \quad a_{12} = -\beta SI, \quad a_{13} = \lambda SM + \lambda_o S_m, \quad a_{14} = \beta SI + \mu E + \eta E + \sigma E + \alpha I$$

$$a_{16} = -\sigma E - \alpha I \quad a_{16} = \sigma E + \alpha I, \quad a_{17} = \sigma E + \mu I + \alpha I + \nu I + \mu I_s + \gamma I, \quad a_{18} = \mu R + \gamma I \omega I_s, \quad a_{19} = kI + k_o M$$

Hence , the stochastic model is presented as

$$d(\vec{X}(t)) = \vec{f}(X(t))dt + \mathbf{V}^{1/2}(t, X(t))dW(t) \quad (9)$$

Where the drift vector \vec{f} of order 7×1 , p_i and $\vec{\lambda}_i$ ($i=1, \dots, 18$) are random changes and transition probabilities represented in the above table.

The diffusion matrix is obtained from the entries $p_i \vec{\lambda}_i$ as

$$G = \begin{pmatrix} \sqrt{\Lambda} & -\sqrt{\mu S} & -\sqrt{\beta SI} & -\sqrt{\lambda SM} & 0 & 0 & 0 & 0 & 0 & 0 & 0 & 0 & 0 & 0 & \sqrt{\lambda_o S_m} & 0 & 0 & 0 \\ 0 & 0 & \sqrt{\beta SI} & 0 & -\sqrt{\mu E} & -\sqrt{\eta E} & -\sqrt{\sigma E} & 0 & 0 & 0 & 0 & 0 & 0 & 0 & 0 & 0 & 0 & 0 \\ 0 & 0 & 0 & 0 & 0 & 0 & \sqrt{\sigma E} & -\sqrt{\mu I} & -\sqrt{\alpha I} & -\sqrt{\gamma I} & -\sqrt{\nu I} & 0 & 0 & 0 & 0 & 0 & 0 & 0 \\ 0 & 0 & 0 & 0 & 0 & \sqrt{\eta E} & 0 & 0 & \sqrt{\alpha I} & 0 & 0 & -\sqrt{\mu I_s} & -\sqrt{\omega I_s} & 0 & 0 & 0 & 0 & 0 \\ 0 & 0 & 0 & \sqrt{\lambda SM} & 0 & 0 & 0 & 0 & 0 & 0 & 0 & 0 & 0 & -\sqrt{\mu S_m} & -\sqrt{\lambda_o S_m} & -\sqrt{\mu R} & 0 & 0 \\ 0 & 0 & 0 & 0 & 0 & 0 & 0 & 0 & 0 & \sqrt{\gamma I} & 0 & 0 & \sqrt{\omega I_s} & 0 & 0 & 0 & 0 & 0 \\ 0 & 0 & 0 & 0 & 0 & 0 & 0 & 0 & 0 & 0 & 0 & 0 & 0 & 0 & 0 & 0 & \sqrt{kI} & -\sqrt{k_o M} \end{pmatrix}$$

and

$$\vec{W} = [W_1, W_2, W_3, W_4, W_5, W_6, W_7, W_8, W_9, W_{10}, W_{11}, W_{12}, W_{13}, W_{14}, W_{15}, W_{16}, W_{17}, W_{18}]^T \quad (10)$$

is a Vector of eighteen independent Wiener processes. In addition, $d\vec{W}(t)$ has order 18×1 While $d\vec{X}$ is a 7×1 dimensional vector. f_i are given as;

$$\left. \begin{aligned}
 f_1 &= \Lambda - \mu N - \nu I \\
 f_2 &= \beta(N - E - I - I_s - S_m - R)I - (\sigma + \eta + \mu)E \\
 f_3 &= \sigma E - (\gamma + \alpha + \nu + \mu)I \\
 f_4 &= \eta E + \alpha I - (\omega + \mu)I_s \\
 f_5 &= \lambda(N - E - I - I_s - S_m - R)M - (\mu + \lambda_0)S_m \\
 f_6 &= \gamma I + \omega I_s - \mu R \\
 f_7 &= kI - k_0 M
 \end{aligned} \right\} \quad (11)$$

Thus, the elements of the diffusion matrices are;
Hence,

$$\|f\| = \sqrt{\sum_{i=1}^7 f_i(x)^2} \quad \text{and} \quad \|G\| = \sqrt{\sum_{i=1}^7 \sum_{j=1}^{16} g_{i,j}(x)^2} \quad (12)$$

Where

$$\|f\| = \sqrt{[f_1]^2 + [f_2]^2 + [f_3]^2 + [f_4]^2 + [f_5]^2 + [f_6]^2 + [f_7]^2}$$

and

$$\|G\| = \sqrt{2(\beta SI + \lambda SM + \lambda_0 S_m + \eta E + \sigma E + \alpha I + \gamma I + \omega I_s) + \Lambda + \mu S + \mu E + \mu I + \nu I + \mu I_s + \mu S_m + \mu R + \kappa I + \kappa_0 M}$$

Both f_i and $g_{i,j}$ are continuously differentiable at S, E, I, I_s, S_m, R, M and hence satisfy the Lipchitz condition by (mean value theorem), since norm exist they are bounded. The drift and the diffusion matrices are therefore bounded, hence satisfy the condition for existence.

3. RESULT AND DISCUSSION.

This section focused on numerical interpretation of the stochastic model using Euler Maruyama method coded with Matlab (Fadugba *et al* 2013). (Zafer *et al*,2017) and (Zizhen *et al* 2020) .The numerical results were presented graphically followed by the discussion .

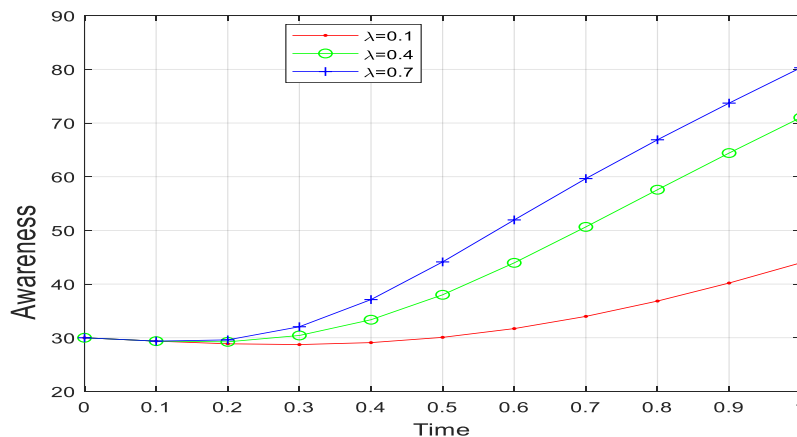

Figure 2. Graph of Awareness for varying value of λ

It was observed from figure 2 that when λ is increases from 0.1 to 0.4, the aware population is increasing, at time (year) = 0.4, the aware population when is 30 when $\lambda = 0.1$ while it is 35 when $\lambda = 0.4$. Also, it increases from 70 to 80 when λ is increases from $\lambda = 0.4$ to $\lambda = 0.7$. This also may be as a result of awareness of preventive measure.

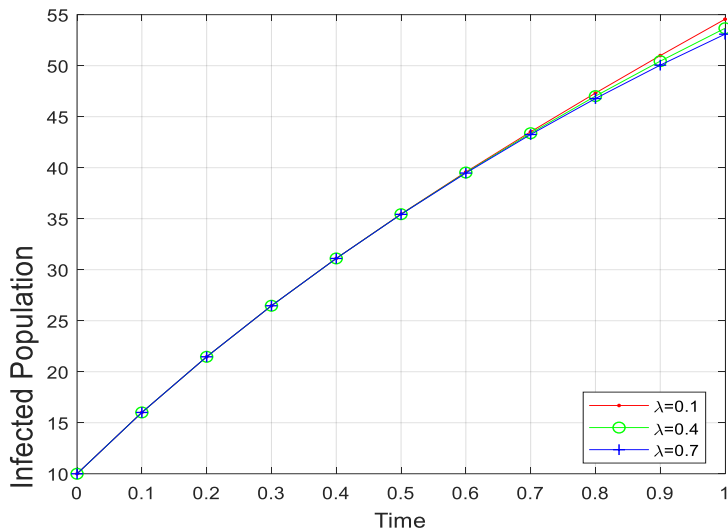

Figure 3. Graph of Infected Population for varying value of λ

It was observed from figure 3 that when λ is increases from 0.1 to 0.4, the infected population is decreasing, at time (year)=0.9, the infected population is 54 when $\lambda = 0.1$ while it is 52 when $\lambda = 0.4$. Also, it decreases from 52 to 49 when λ is increases from $\lambda = 0.4$ to $\lambda = 0.7$.

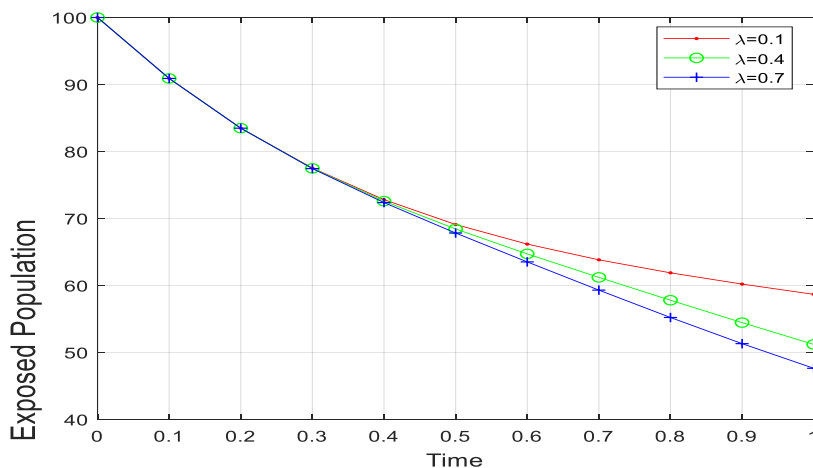

Figure 4. Graph of Exposed Population for varying value of λ

It was observed that figure 4 display similar behavior as fig.3, the expose population decreases , at time (year)=0.9, the infected population move from 60 to 55 and 51 when λ is increases from $\lambda = 0.1$, $\lambda = 0.4$ and $\lambda = 0.7$ respectively.

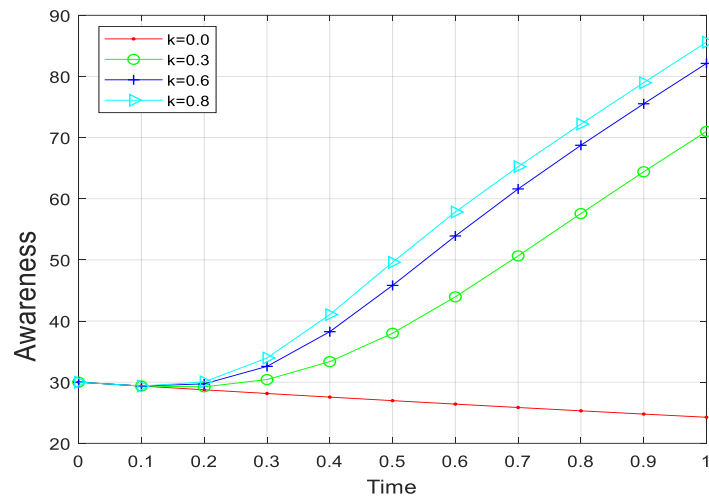

Figure 5. Graph of Awareness for varying value of k

It was observed from figure 5 that when k is increases from 0.0 to 0.3, the awareness population is increasing, at time (year)=0.5, the awareness population moves from 27 to 48, it also increases from 69 to 740 when k is increases from $k = 0.6$ to $k = 0.8$.

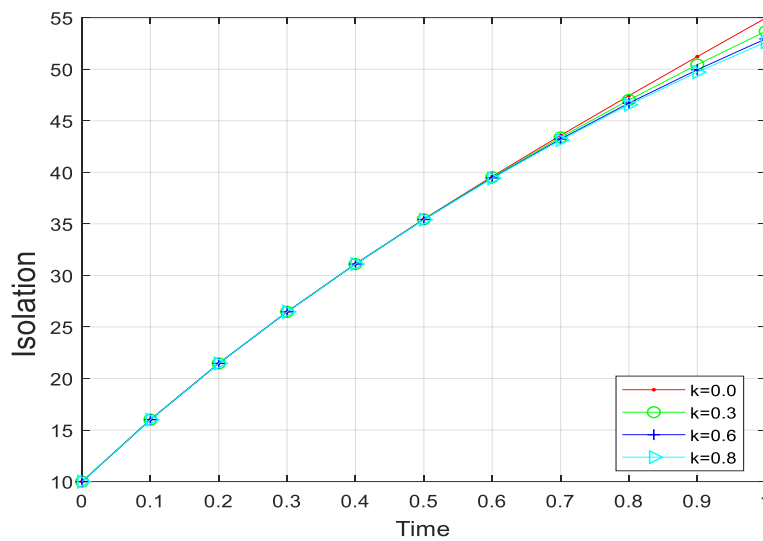

Figure 6. Graph of Isolation for varying value of k

It was observed from figure 6 that when k is increases from 0.0 to 0.3, the isolation population is decreasing, at time (year)=0.8, the awareness population moves from 53 to 50.

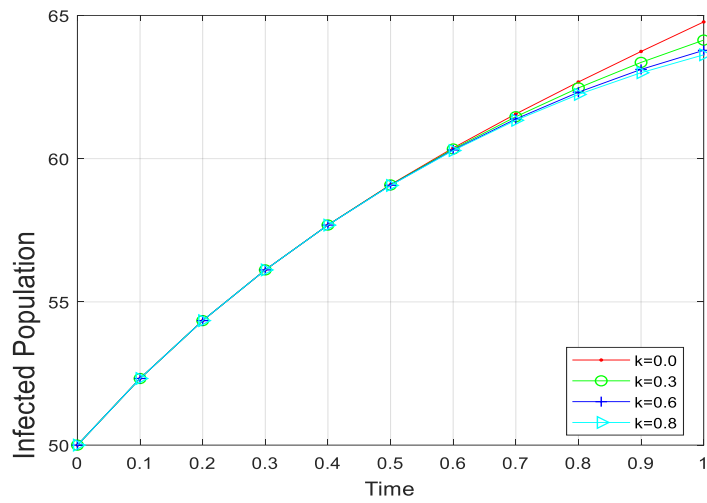

Figure7. Graph of Infected for varying value of k

It was observed from figure 7 that when k increases from 0.0 to 0.3, the infected population is decreasing, at time (year)=0.5, the infected population moves from 27 to 48, it also decrease from 74 to 69 when k is increases from $k = 0.6$ to $k = 0.8$.

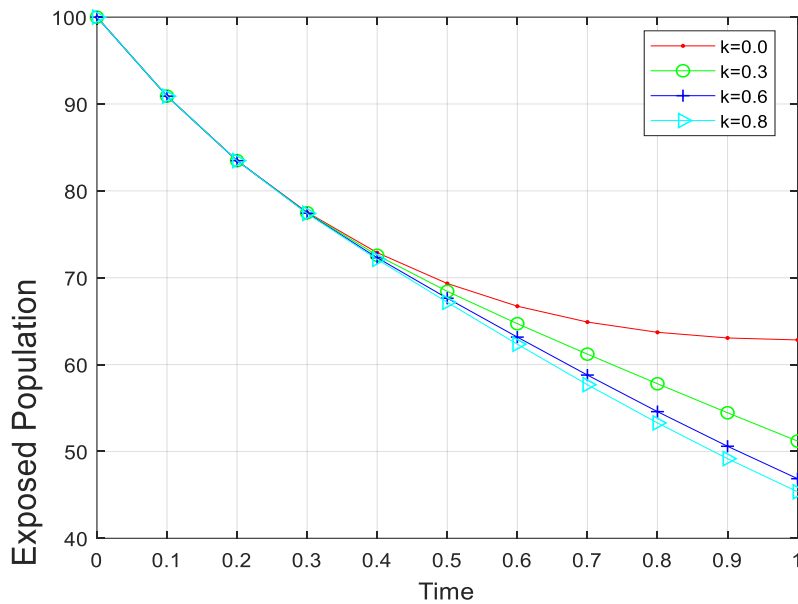

Figure.8. Graph of Awareness for varying value of k

It was observed from figure 8 that when k is increases from 0.0 to 0.3, the Exposed population is decreasing, at time (year)=0.5, the awareness population moves from 48 to 27, it also increases from 74 to 69 when k is increases from $k = 0.6$ to $k = 0.8$.

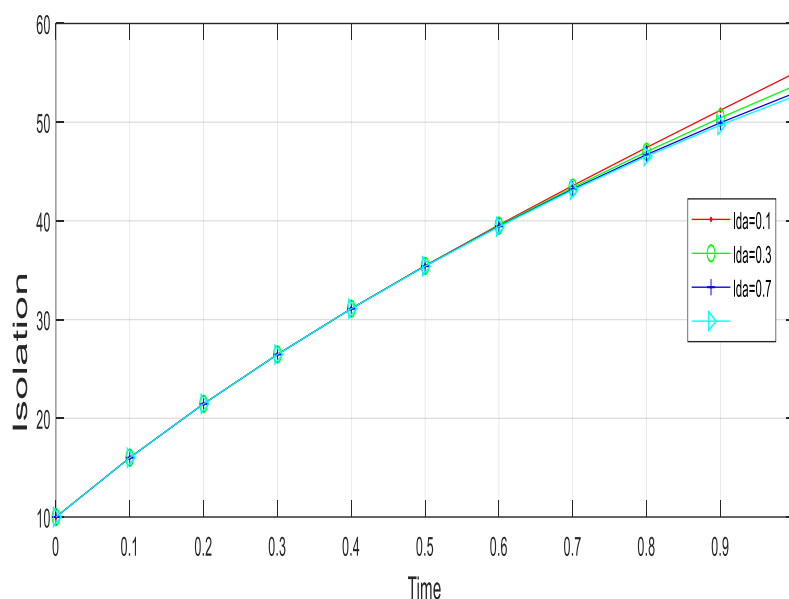

Figure 9. Graph of Isolation for varying value of λ

It was observed from figure 9 that when λ increases from 0.1 to 0.3, the isolation population is decreasing, at time (year) =0.8, the awareness population moves from 53 to 50

4. CONCLUSION

In order to examine the impact of media-driven awareness campaigns on the spread of COVID-19, a modified dynamic model to stochastic model for the COVID-19 transmissions was developed and examined in this work. According to the model study, COVID-19 extinction will result from an increase in the rate at which awareness activities are implemented.

References

- Asamoah J.K.K, Jin Z, Sun G.Q, Seidu B, Yankson E, Oduro F, Abidemi A, Moore S.E, Okyere E (2021): Sensitivity assessment and optimal economic evaluation of a new COVID – 19 compartmental epidemic model with control interventions. *Chaos Solitons Fractals* 146, 110885, <https://doi.org/10.1016/j.chaos.2021.110885>
- Asamoah J.K.K, Owusu M.A, Jin Z, Oduro F, Abidemi A, Gyasi E.O (2020): Global stability and cost – effectiveness analysis of COVID – 19 considering the impact of the environment: using data from Ghana . *Chaos Solitons Fractals* 140,110103 <https://doi.org/10.1016/j.chaos.2020.110103>
- Abdo, M.S., Hanan, K.S., Satish, A.W., Pancha, K.: (2020): On a comprehensive model of the novel coronavirus (COVID-19) under mittag – Leffler derivative, *Chaos solutions fractals* 135, Article ID 109867.
- Al – qaness, M.A.A , Ewees, A.A, Fan H, Aziz, A. El bd and EI, M.A (2020). Optimization methodfor forecasting confirmed cases of COVID – 19 in China. *Journal of clinical Medicine*, 9, 674. <https://doi.org/10.3390/jcm9030674>.
- Allen E.J, Allen L.J.S, Arciniega A, Greenwood P.E (2008): Construction of Equivalent Stochastic Differential Equation Models; *Stoch. Anal. Appl.*26(2): 274 – 297.
- Allen, L.J.(2008): An introduction to stochastic epidemic models, In *Mathematical epidemiology* (pp. 81-130), Springer,Berlin, Heidelberg.

- Allen L. J. S. and Jr. L.,(2012): Extinction thresholds in deterministic and stochastic epidemic models, *Journal of Biological Dynamics*, 6, pp. 590–611.
- Anastassopoulou, C, Russo, I, Tsakris A and Siettos C(2020). Data – based analysis, modeling and forecasting of the COVID -19 outbreak. *PLoS One*, 15, Article e0230405. <https://doi.org/10.1371/journal.pone.0230405>.
- Ayinde, K, Lukman A.F, Rauf I.R, Alabi O.O, Okon C.E and Ayinde O.E (2020): Modeling Nigerian COVID – 19 cases: A comparative analysis of models and estimators. *Chaos, Solitons and fractals*,138, Article 109911.
- Bastista M (2020): Estimation of the final size of the coronavirus epidemic by SIR model. *Research Gate*.
- Djordjevic J, Silva C.J, Torres DFM (2018): A Stochastic SICA Epidemic model for HIV transmission. *Appl. Math. Let.*; 84: 168 – 175. Doi:10.1016/jani.2018.005.
- Engbert R, Rabe MM, Kliegl R, Reich S (2020) Sequential data assimilation of the stochastic SEIR epidemic model for regional COVID-19 dynamics. *Bull Math Biol* 10000:1000. <https://doi.org/10.1101/2020.04.13.200637687>
- Fadugba, S.E., Adegboyegun, B.J. and Ogunbiyi, O.T. (2013) On Convergence of Euler Maruyama and Milstein Scheme for Solution of Stochastic Differential Equations. *International Journal of Applied Mathematics and Modeling*, 1, 9-15
- Hay Yoba Talkibing , Barro Diakarya and Ouoba Fabrice (2019): Stochastic approach of epidemic model using the SEIRS; *European Journal of Pure and Applied Mathematics*. 12 (3) Pg 834 – 845.
- Higham, D(2001): An algorithmic introduction to numerical simulation of stochastic differential equations. *SIAM Rev.* 43, 525 – 546.
- He Sha, Sanyi Tang and Libin Rong (2020): A discrete Stochastic model for the COVID – 19 Outbreak: forecast and control. *Mathematical Biosciences and Engineering*. Vol.17, issue 4:2792 – 2804 doi:10.3934/inbe.2020153.
- Ito K (1951): On Stochastic Differential Equation “memoirs of American Mathematical Society (4): 1 – 51.
- Wu J, Fred Brauer and Pauline Van den Driessche (1945): Lecture Note in Mathematics. In *Oxford Mathematical Biosciences subseries: P.K Maini, editor, Mathematical Epidemiology*.
- Jumanne M. Mnganga and Naboth Sindi Zachariah (2020): Mathematical Model of COVID – 19 Transmission dynamics and control strategies. *Journal of Applied and Computational Mathematics*. Vol. 9:1. DOI : 10.37421/jacm.2020.9.453
- Kumama Regassa and Purnachandra Rao Koya (2019): Modelling and Analysis of Population Dynamics of Human Cells Pertaining to HIV/AIDS with Treatment, *American Journal of Applied Mathematics*. Vol. 7, No. 4, Pp127 – 136. Doi :10.11648/j.ajam.20190704.14.
- Liu .Z, Magal P, Seydi O, Webb . C (2020): understanding unreported cases in the 2019-ncov epidemic outbreak in Wuhan,China and importance of major public Health intervention, *MPDI biology*, 9(3) P.50.
- Misra A.K, Anupama Sharma and Shukla J.B(2011): Modeling an analysis of effects of awareness programs by media on the spread of infectious diseases. *Mathematical and Computer Modeling*. 53: 1221 – 1228.
- Mohamed Coulibaly* and Modeste N’zi (2021): A Stochastic Model with Jumps for the COVID-19 Epidemic in the Greater Abidjan Region during Public Health Measures. *J. Infect Dis Epidemiol* 2021, 7:196 Volume 7 | Issue 3 DOI: [10.23937/2474-3658/1510196](https://doi.org/10.23937/2474-3658/1510196)

- Nesteruk I (2020): Statistics – based predictions of coronavirus epidemic spreading in Mainland China, “ innovative Biosystems and Bioengineering, vol. 4, no 1, pp 13 – 18.
- Ndii, M.Z. and Supriatna, A.K.(2017): Stochastic mathematical models in epidemiology, Information, 20(9A), pp.6185-6196.
- Ndairou F, Area I, Nieto J.J and Silva C.J (2018): Mathematical modeling of Zika disease in pregnant women and newborn with microcephaly in Brazil. Math Methods Appl Sci 41:89. 29 – 41.
- Rihan F.A, Alsakaji H.J and Rajivganthi C (2020) : Stochastic SIRC epidemic model with time delay for COVID-19. *Advances in Difference Equations* ,2020:502 <https://doi.org/10.1186/s13662020-02964-8>
- Rodrigues HS, Monteiro MTT, Torres DFM (2013). Sensitivity analysis in a dengue epidemiological model. Conference papers in mathematics. Hindawi, editor. Doi: 10.1155/2013/721406.
- Stephen E, Kitengeso R.E, Kiria G.T and Felician N (2015): A Mathematical model for control and Elimination of the transmission dynamics of measles. Appl Math Comput 4:396 – 408.
- Sultan Hussain, Anwar Zeb, Akhter Rasheed and Tareq Saeed (2020): Stochastic mathematical model for the spread and control of Corona virus. *Advances in Difference Equations* , 2020:574. <https://doi.org/10.1186/s13662-020-03029-6>
- Tang .B, Bragazzi N.L, Li O, Tang .S, Xio .Y, Wu .J(2020): An updated estimation of the risk of transmission of the novel corona virus (2019-nCov). Infectious disease modeling, 5, pp 248 – 255
- Van D.P and Watmough J (2020): “Reproduction number and sub – threshold endemic equilibria for compartmental models of disease transmission” Math. Biosci/180 :29 – 48.
- W. Ming, J.V. Huang and C.J.P Zhang (2020): Breaking down of the healthcare system: mathematical modeling for controlling the novel coronavirus (2019 – nCoV) outbreak in Wuhan, China, medRxiv and bioRxiv.
- Zafer Bekiryazia, Tulay Kasemen and Mehmet Merdan (2017) : Stochastic and random models of malaria disease with vertical transmission. New trends in Mathematical Sciences; 5(1).Pg 269 – 277. Doi.org/10.20852/ntmsci.2017.146.
- Zizhen .Z, Anwar .Z, Sultan .H and Ebraheem .A(2020): Dynamics of COVID – 19 Mathematical model with stochastic perturbation. *Advances in Difference Equations* , 2020:451. <https://doi.org/10.1186/s13662-020-02909-1>